

Italia
2020



**“ dagli anni Novanta
il nostro stile
inconfondibile ”**

#imsostone

**Sezione
ITALIA**

**Prodotti
MadeInItaly**





ITALIA

caratteristiche prodotti imballi

MATERIALS

Marmo
Statuario Apuano

Marmo
Bianco Carrara

Marmo
Bardiglio Scuro

Marmo
Bardiglio Chiaro

Marmo
Travertino Chiaro

Marmo
Nero Marquina

SHAPE

Quadrata

Rettangolare

Cilindro

Astratto

Simmetrie

Pezzi unici e irripetibili di finissimo e rarissimo marmo totalmente made in Italy scolpito a regola d'arte per lasciare intatta la caratteristica tecnica ed estetica della materia prima naturale. Ogni lavabo ha venature caratteristiche che lo rendono unico per forma e accento cromatico.

Unique pieces of rare made in Italy marble perfectly sculpted in order to leave the technical characteristic and aesthetics of raw material intact. Every sink has his own characteristics veins that make each piece unique by shape and chromatic accent.

Pièces uniques de précieux marbre italien parfaitement sculpté aux règles de l'art pour laisser intactes les caractéristiques techniques et esthétiques de la matière première. Tous les vasque ont des caractéristiques qui font que chaque vasque sois unique par sa forme et couleur.

Bei den in Italien produzierten Becken, handelt es sich um Einzelstücke aus hochwertigen -und sehr seltenen Marmor. Jedes einzelne Produkt ist in ein Unikat, welches mit der charakteristischen Aderung und dem fein abgestimmten Farbspiellhre Eleganz hervorhebt. Die perfekte Verarbeitung des Materials trägt dazu bei, die ästhetischen Eigenschaften des natürlichen Rohstoffs zu erhalten.

Уникальные и неповторимые изделия из очень тонкого и чрезвычайно редкого мрамора, полностью изготовленные в Италии, доведены до совершенства таким образом, чтобы оставить неповрежденными его техническую и эстетическую характеристику. Каждый умывальник имеет характерные вены, которые делают его уникальным как по форме так и в цветовых акцентах.



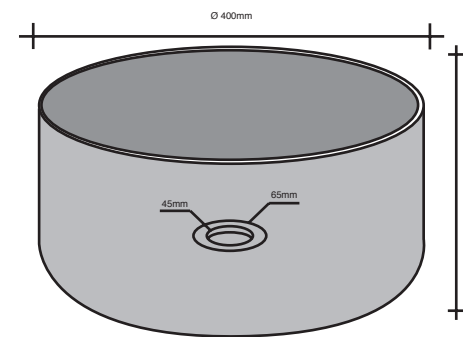

BIANCO CARRARA CILINDRO

CODE	ISBABICAC
COLOUR	Chiaro
DIMENSIONS	d.40 - h.18
MATERIAL	Marmo
SURFACE FINISH	Levigata
KG / PZ	25
PRICE BAND	04

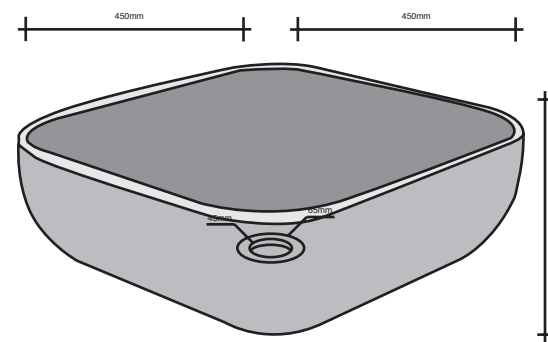

BIANCO CARRARA QUADRATO

CODE	ISBABICAQ
COLOUR	Chiaro
DIMENSIONS	45x45 h18 cm
MATERIAL	Marmo
SURFACE FINISH	Levigata
KG / PZ	25
PRICE BAND	06

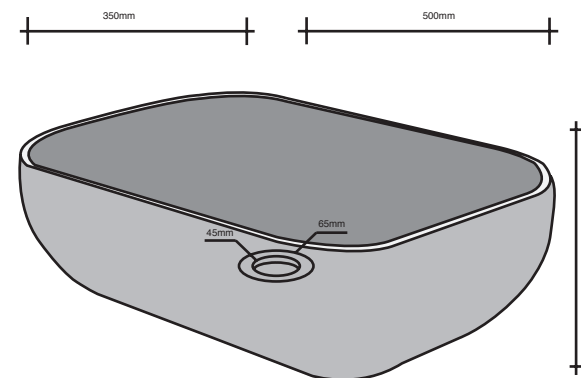

BIANCO CARRARA RETT.

CODE	ISBABICAR
COLOUR	Chiaro
DIMENSIONS	35x50 h18 cm
MATERIAL	Marmo
SURFACE FINISH	Levigata
KG / PZ	25
PRICE BAND	06



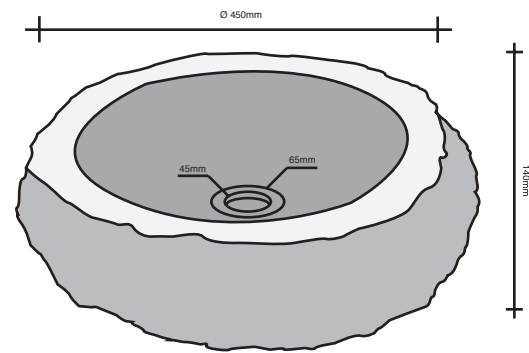

STATUARIO APUANO ASTRATTO

ISBASTAPQ	ISBASTAPA
COLOUR	Chiaro
DIMENSIONS	d.45 - h.18 cm14
MATERIAL	Marmo
SURFACE FINISH	Levigata
KG / PZ	40
PRICE BAND	02

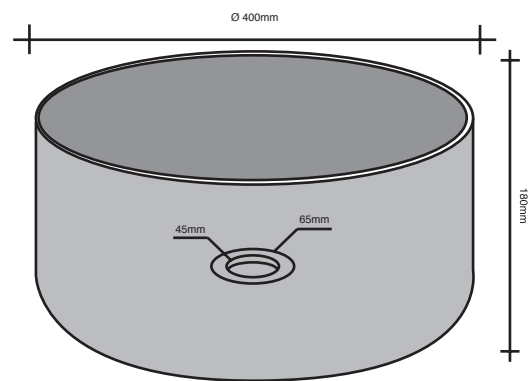

STATUARIO APUANO CILINDRO

CODE	ISBASTAPC
COLOUR	Chiaro
DIMENSIONS	d.40 - h.18
MATERIAL	Marmo
SURFACE FINISH	Levigata
KG / PZ	25
PRICE BAND	05

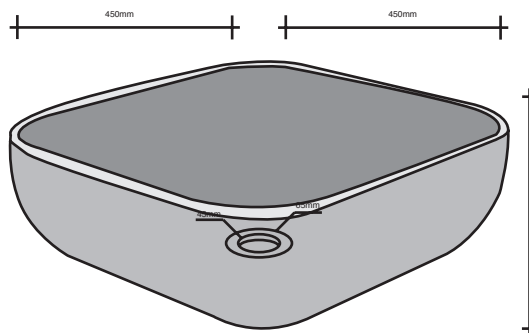

STATUARIO APUANO QUADRATO

ISBASTAPQ	ISBASTAPQ
COLOUR	Chiaro
DIMENSIONS	45x45 h.18 cm
MATERIAL	Marmo
SURFACE FINISH	Levigata
KG / PZ	25
PRICE BAND	06



30x90 Imperiale Stripe Grey - 30x90 Imperiale Grey - 60x60 Bibulca Grey



Spaccatello Snow White
10x35



Statuario apuano
Simmetrie



Hermitage Coal
120x120

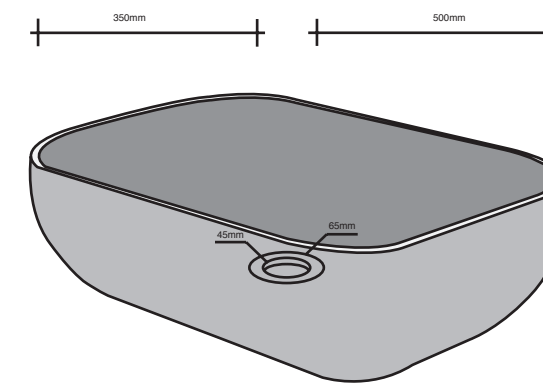

STATUARIO APUANO RETT.

CODE	ISBASTAPR
COLOUR	Chiaro
DIMENSIONS	35x50 h18 cm
MATERIAL	Marmo
SURFACE FINISH	Levigata
KG / PZ	25
PRICE BAND	06

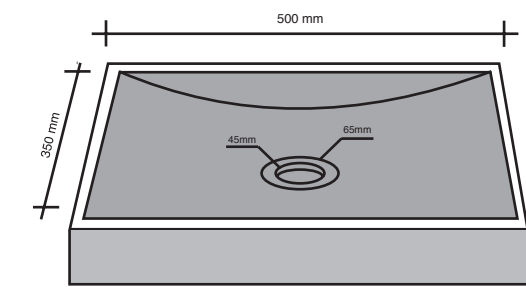

STATUARIO APUANO SIMMETRIE

CODE	ISBASTAPS
COLOUR	Chiaro
DIMENSIONS	35x50 h14 cm
MATERIAL	Marmo
SURFACE FINISH	Levigata
KG / PZ	40
PRICE BAND	03

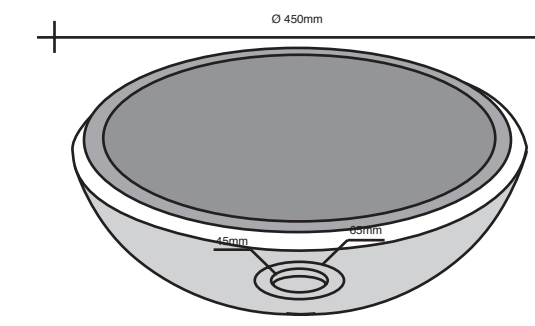

STATUARIO APUANO TONDO

ISBASTAPQ	ISBASTAPT
COLOUR	Chiaro
DIMENSIONS	d.40 - h.14 cm
MATERIAL	Marmo
SURFACE FINISH	Levigata
KG / PZ	25
PRICE BAND	04

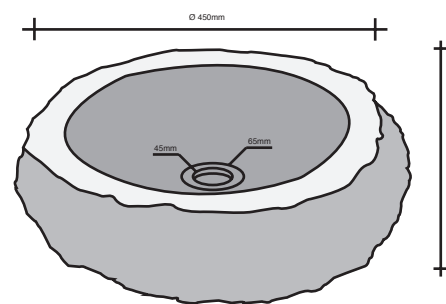
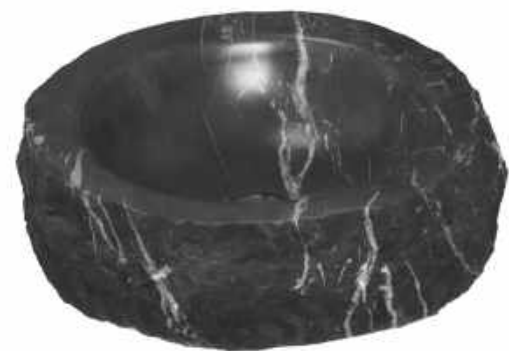

MARQUINIA ASTRATTO

ISBASTAPQ	ISBANEMAA
COLOUR	Scuro
DIMENSIONS	d.45 - h.14 cm
MATERIAL	Marmo
SURFACE FINISH	Levigata
KG / PZ	40
PRICE BAND	02

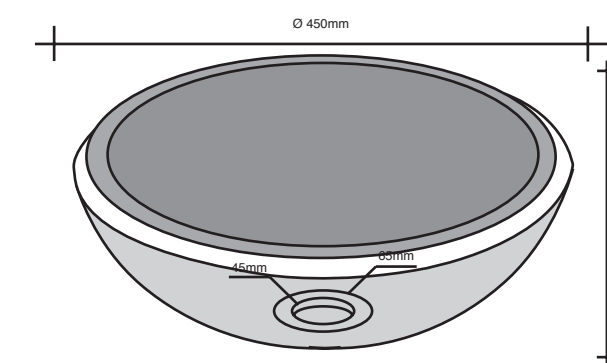

MARQUINIA ASTRATTO

ISBASTAPQ	ISBANEMAA
COLOUR	Scuro
DIMENSIONS	d.45 - h.14 cm
MATERIAL	Marmo
SURFACE FINISH	Levigata
KG / PZ	40
PRICE BAND	04

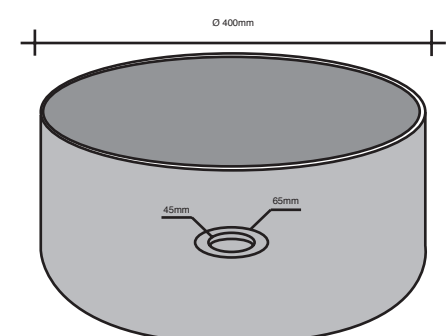

MARQUINIA CILINDRO

CODE	ISBANEMAC
COLOUR	Scuro
DIMENSIONS	d.40 - h.18 cm
MATERIAL	Marmo
SURFACE FINISH	Levigata
KG / PZ	25
PRICE BAND	05

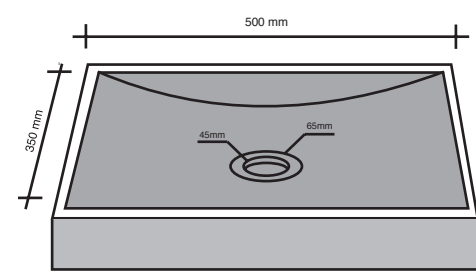

MARQUINIA SIMMETRIE

CODE	ISBANEMAS
COLOUR	Scuro
DIMENSIONS	35x50 h14 cm
MATERIAL	Marmo
SURFACE FINISH	Levigata
KG / PZ	40
PRICE BAND	04



Nero Marquinia
Tondo

Tramezzo Antracite
15x60



Hermitage Ivory
120x120



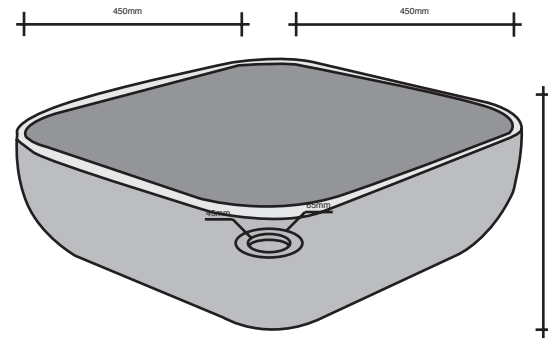

BARDIGLIO SCURO QUADRATO

CODE	ISBABASCQ
COLOUR	Scuro
DIMENSIONS	45x45 h18 cm
MATERIAL	Marmo
SURFACE FINISH	Levigata
KG / PZ	25
PRICE BAND	06

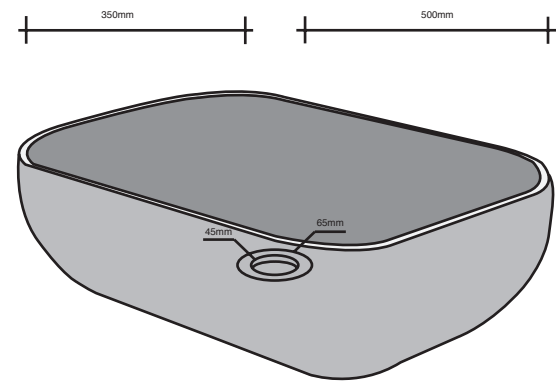

BARDIGLIO SCURO RETT.

CODE	ISBABASCR
COLOUR	Scuro
DIMENSIONS	35x50 h18 cm
MATERIAL	Marmo
SURFACE FINISH	Levigata
KG / PZ	25
PRICE BAND	06

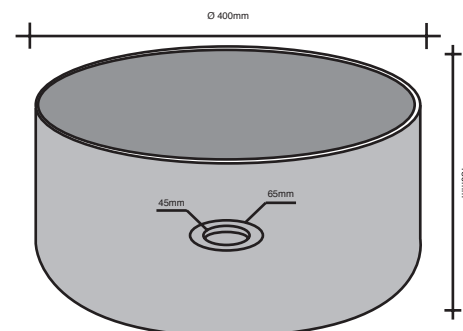

BARDIGLIO CHIARO CILINDRO

CODE	ISBABACHC
COLOUR	Chiaro
DIMENSIONS	d.40 - h.18 cm
MATERIAL	Marmo
SURFACE FINISH	Levigata
KG / PZ	25
PRICE BAND	05



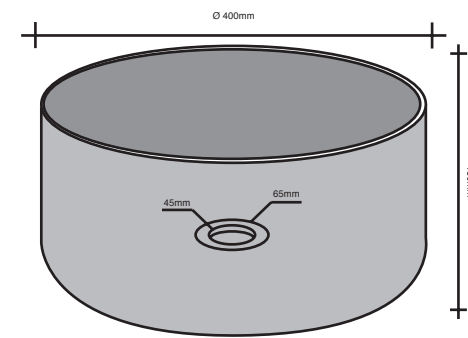

TRAVERTINO CHIARO CILINDRO

CODE	ISBATRCHC
COLOUR	Chiaro
DIMENSIONS	d.40 - h.18 cm
MATERIAL	Marmo
SURFACE FINISH	Levigata
KG / PZ	25
PRICE BAND	05



MOS. 5x5 STATUARIO APUANO

CODE	ISBAMOSAS
DIMENSIONS	30x30 cm
KG / PZ	1,9
PZ / BOX	6
KG / BOX	11,4
PRICE BAND	01



MOSAICO 5x5 BIANCO CARRARA

CODE	ISBAMOBC5
DIMENSIONS	30x30 cm
KG / PZ	1,9
PZ / BOX	6
KG / BOX	11,4
PRICE BAND	01

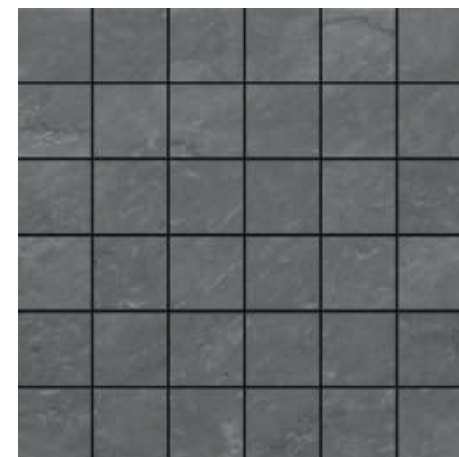

MOSAICO 5x5 BARDIGLIO SCURO

CODE	ISBAMOBS5
DIMENSIONS	30x30 cm
KG / PZ	1,9
PZ / BOX	6
KG / BOX	11,4
PRICE BAND	01

CONDIZIONI GENERALI DI VENDITA

1 - APPLICABILITY OF CONDITIONS

1.1 These general conditions (the "CONDITIONS") constitute the most important part of each contract of sale of tiles and any other ceramic material (the "PRODUCTS") in which IMSO CERAMICHE (the MANUFACTURER) is one of the parties. Excepted single cases in which they have been derogated by explicitly written agreements signed by the MANUFACTURER, they will constitute the exclusive discipline of such sales. If one or more parts of these CONDITIONS, or of single contracts including them, result to be invalid, the general or the particular CONDITIONS will remain valid as a whole: invalid parts will be substituted through agreements that are as close as possible to the original will of the parties.

2 - CONCLUSION OF THE CONTRACT OF SALE - DELIVERY

2.1. The contract is intended to be concluded at the moment in which the written consent of the counterpart has come to the knowledge of the proponent and of the person ordering the contract.
2.2. The order that has not been confirmed in writing cannot be considered accepted in any case, except for the performance of the contract itself by the MANUFACTURER through shipment or delivery of the PRODUCTS. The partial delivery of ordered PRODUCTS doesn't involve that the whole order has been accepted, but only that part of PRODUCTS actually delivered.
2.3. Except a different written agreement, the delivery of PRODUCTS in Italy or abroad will take place "ex-works".
2.4. Except a different agreement, all the dates given as delivery dates are intended in a indicative sense.

3 - CHARACTERISTICS OF THE PRODUCTS - WARRANTY - COMPLAINTS

3.1. Ceramic tiles and other ceramic PRODUCTS produced by IMSO CERAMICHE comply with European norms UNI-DIN-EN. The MANUFACTURER sells exclusively to professional resellers that are responsible for the accuracy of technical informations given to final users and/or to retailers.

The classification of a product is indicated by the MANUFACTURER on advertising material and/or on price lists. Therefore the purchaser must use the PRODUCTS according to the classification given by the MANUFACTURER. To facilitate the directions for the use of products and to adapt standard classifications to the specificity of the production, marks connected with each single product are put in price lists and catalogues, indicating the specific use advised by the MANUFACTURER.

3.2. Differences in the tone are not defects of the PRODUCT but a characteristic of the specific material fired at high temperatures. The particular requisite of frost resistance is applied only to those PRODUCTS explicitly guaranteed by the MANUFACTURER with the relative indication on advertising material and/or price list. In case this indication is not given, ceramic materials are considered only and exclusively for indoor use or use in places protected from bad weather.

3.3. Ceramic materials with polished surface can never be used in places located on the ground floor with access outside or in places with great pedestrian traffic. In addition polished tiles are susceptible for a certain slipperiness especially when they are wet. The MANUFACTURER advises therefore not to use them in public places. In places with great pedestrian traffic the purchase will have to buy only those PRODUCTS classified by the MANUFACTURER as PEI V, and in particular those tiles that the MANUFACTURER advises SPECIFICALLY for use in public places.

3.4. The pictures of the PRODUCTS on leaflets and on other advertising material by the PRODUCER are only illustrative and they don't represent necessarily the final esthetic result of laying of the PRODUCT.

3.5. The MANUFACTURER guarantees the good quality and the absence of defects of the products supplied, the warranty is not applied to those PRODUCTS classified by the MANUFACTURER as non-first-quality products or to lots of PRODUCTS of the end of a series, sold in bulk and pointed out as special lots. However a 5% tolerance is provided.

3.6. The MANUFACTURER is not responsible for defects and/or anomalies found out in the PRODUCTS that are not due to their quality, but to an improper use of them by the purchasers and/or by their assignees. In particular the MANUFACTURER doesn't accept complaints or contestations concerning the above mentioned situation.

3.7. Complaints must be communicated by the purchaser to the MANUFACTURER within 8 days from the delivery of goods. In case of defects, the term is 8 days from the discovery. In any case the MANUFACTURER is not responsible for the defects denounced 12 months after the delivery of the PRODUCTS to the purchaser. In case of hidden defects the warranty is applied up to 2 years after the delivery of the PRODUCTS to the first purchaser. The denunciation of defects must be notified to the MANUFACTURER within and not later than 8 days from the discovery.

3.8. In general the warranty is applied only for defects found out in products that have not yet been layed. In case of hidden defects, detectable only after laying, it's necessary for the MANUFACTURER to verify that the laying has been carried out duly (conforming to DIN 18352).

3.9. The MANUFACTURER's warranty is limited to the substitution of faulty PRODUCTS with other products of the same model without defects, freight included. The reimbursement of other expenses or additional costs, and in particular demolition costs and money paid for a second laying of the PRODUCTS is excluded. In any case the MANUFACTURER's warranty cannot exceed 5 times the value of the contested material, with an absolute maximum of 10.000 euro.

3.10. The MANUFACTURER is not responsible for complaints due to a classification of the ceramic material by foreign bodies for control and/or certification, that is different from the Italian one, according to technical specifications that don't correspond to those used by the MANUFACTURER. In case of technical expertise activated by the purchaser, this must be necessarily based on the conformity of the sold material with the specifications indicated by the MANUFACTURER in force in Italy.

4 - PRICES AND CONDITIONS OF PAYMENT

4.1. The sale prices of PRODUCTS are those indicated in the price list of the MANUFACTURER in force at the moment of the confirmation of the order. In case of contracts of sale and delivery of goods divided in parts, and if there is no written agreement. On the subject, the price is the one indicated in the price list in force at the moment of the delivery of each single portion of goods. For all the PRODUCTS destined to the foreign market prices can be calculated at MANUFACTURER's choice in the foreign currency of the destination country or in Italian lire.

Every bank and negotiation costs have to be debted to the Purchaser. In case of delay in the payment the MANUFACTURER has the right, without the necessity of putting into mora to cash a moratory interest amounting to the official discount rate in Italy, plus 5%, apart from economical damages occurred.

5 - MANUFACTURER'S AGENTS

5.1. The MANUFACTURER's agents promote sales but are not authorized to act in the name and on the behalf of the MANUFACTURER, except in case of a specific written permission.

5.2. The orders transmitted by the agents don't bind the MANUFACTURER. Therefore they must be accepted explicitly in writing by the MANUFACTURER.

6 - RESERVED DOMINION

6.1. It's agreed between the parties that the sale of the PRODUCTS is carried out with reserve of propriety in favour of the MANUFACTURER up to the total payment of the agreed price, according to the Italian Civil Code, art. 1523 and following. However the risk of deterioration of the goods passes to the purchaser from the moment of delivery of the PRODUCTS. In the sales of the PRODUCTS abroad, in case the goods are sold and delivered to third customers before the transfer of title, within the ordinary trade relations of the purchaser himself, the reserve of property in favour of the MANUFACTURER remains also towards third customers, when the law permits it.

6.2. In case of mora of the Purchaser, the MANUFACTURER can take back all the goods object of reserved dominion without any formality, included the putting into mora, and if the law permits it, all documents of credit to third people relative to these goods, with reserve of any proper legal remedy for the prejudices suffered.

7 - SUPERIOR FORCE

7.1. The MANUFACTURER is not responsible towards the Purchaser for non-fulfillment, included non-delivery or delay in delivery due to events outside his reasonable control, as for example non-delivery or delay in delivery of materials by the suppliers, breakdown of plants, strikes or other sindical actions, interruption of energy supply, interruption or difficulty of transports.

8 - APPLICABLE LAW - COMPETENT COURTS

8.1. The contracts of sale to export in which the MANUFACTURER is one of the party are governed by the Italian law and in particular by the "Preservation of International Contracts of Sale" of movables, where it's not derogated by these CONDITIONS and by the Convention of Vienna (11 April 1 980).

8.2 The competent court for any controversy concerning the sale of the PRODUCTS by the MANUFACTURER and the trade relation connected with the above mentioned sales is the court of the registered office of the MANUFACTURER, even when the legal action started concerns documents of credit released to the MANUFACTURER, as means of payment.

IMS©
CERAMICHE